

**Loadmaster 9000i /DMM
/Scanner Module
On-Board Weighing System
Calibration**

RDS Part No.:	S/DC/500-10-591
Document Issue:	2.2.1: 27/1/09
Software Issue:	PS314-018 rev. 15 (Approved mode) PS306-051 rev. 00 (DMM) PS309-003 rev.00 (Scanner Module)

Electromagnetic Compatibility (EMC)



This product complies with Council Directive 89/336/EEC when installed and used in accordance with the relevant instructions.

Service and Technical Support

PLEASE CONTACT YOUR NEAREST DISTRIBUTOR

If unknown then fax +44 (0) 1453 733311 for further information.

Our policy is one of continuous improvement and the information in this document is subject to change without notice.

Check that the software reference matches that displayed by the instrument.

© Copyright RDS Technology LTD 2009

\\UK591221.DOC

OVERVIEW	5
Loadmaster 8000i (Non-Approved Weighing)	5
Loadmaster 9000i (Approved Weighing)	5
Loadmaster 9000 DMM	5
1 LOADMASTER 8000I CALIBRATION	6
1.1 Calibration summary	6
2 LOADMASTER 8000I/9000I - COMMON CALIBRATION	7
2.1 Sensor Setup	7
2.1.1 General setup for loading shovels (LM 8000i)	8
2.2 Auto Cal	9
2.2.1 'Dynamic Full Lift'	9
Fast Speed calibration (Use Loaded Bucket)	9
Slow Speed calibration	9
2.2.2 'Static Full Lift'	9
2.2.3 'Live Static Comp'	10
2.2.4 "Dynamic Empty Lift"	10
2.2.5 'Static Empty Lift'	10
2.2.6 Zero	11
2.2.7 Cal Weight (Weight Calibration)	11
Dynamic Calibration Routine	11
Static Calibration Routine	12
2.2.8 Angle Calibration (LM 9000i -optional on LM8000i)	12
Zero	12
2.2.9 Temperature Calibration (LM 9000i only)	13
2.3 Calibration Factors	14
2.3.1 Displaying Static/Dynamic Factors	14
2.3.2 Dynamic Speed Compensation Factors (Dyn. Comp. Factors)	14
2.3.3 Static Speed Compensation Factors (Stat. Comp. Factors)	15
2.3.4 Surge Setup (optional on LM 8000i)	16
2.3.5 Angle Factors (Optional Angle Sensor)	16
2.3.6 Temperature Factors (LM 9000i only)	17
2.3.7 Linear Factor	17
2.4 'NUDGE' Calibration	18
When to nudge the calibration (LM 8000i only)	18
How to nudge the calibration	18
2.5 Calibrating alternative attachments	19
2.5.1 Programming an attachment	19
2.5.2 Select an attachment for calibration	19
2.5.3 Calibrating an alternative attachment	19
3 LOADMASTER 9000I CALIBRATION	20
3.1 Calibration Summary	20
3.2 Certification	21
3.2.1 Setting the Certification Defaults	21
OIML R76 NAWI (Class III), (1000 to 25,000kg)	22
OIML R51 AWI (y(a)/y(b) (1000 kg - 25,000 kg)	22
3.2.2 Completing the Data Plate and Anti-tamper Measures	22

4	LM8000I / LM9000I - GENERAL SYSTEM SETTINGS	25
4.1	Output Port Setup (LM8000i / 9000i)	25
4.1.1	Set Output Mode.....	25
	ASCII Text Output for Printers.....	25
	Input/Output to the RDS Data Card Module.....	26
	Input/Output via Radio Modem (LM8000i / 9000i)	26
	Input/Output via GSM Modem (LM8000i / 9000i).....	26
4.2	Weighing Units	26
	Units	26
	Resolution	26
	Maximum Weight	27
	Overload Log	27
4.3	Bleep Setup	27
4.4	Change PIN Numbers	27
4.5	Reset Factors	27
4.6	Store / Restore / Print Cal Data	28
4.7	Telemetry Option - Enable/Disable (LM8000i / LM9000i)	28
4.8	'Module'	28
5.	THE SETUP MENU	29
6.	OPERATING PARAMETERS	31

Overview

Loadmaster 8000i (Non-Approved Weighing)

- ?? The LoadMaster 8000i weighing system is installed mainly on Front End Loaders. Two pressure sensors are mounted on each of the hydraulic lift system. They provide an increase of frequency signal as the load increases. The average frequency is captured at a set weighing point provided by the Reference/Direction sensor assembly. Calculated with a factor, the system weighs the contents in the bucket being lifted. This information can then be saved to a certain customer or product memory store.
- ?? The LM 8000i system operates in a Non-Approved weighing mode. Dynamic or Static weighing is possible. The system is designed to be easily upgradable for Weights and Measures approved operation, either for automatic weighing (AWI) or non-automatic weighing (NAWI).
- ?? There are a large number of functions within the calibration menu in order to optimise the performance of the weighing system for a particular loading shovel and the method in which it is to be used. Many settings need only be made on the initial installation.
- ?? The calibration procedure is summarised in section 1.1. For full information on any of the settings in the calibration menu, please refer to sections 2.1 through 2.5.

Loadmaster 9000i (Approved Weighing)

- ?? The Loadmaster 9000i is an approvable system. In order to meet the requirements for certification, the system has a Secondary Software Module and several additional sensors to the LM 8000i system. The calibration menu is very similar, with some additional settings for the extra sensors.
- ?? All calibration is performed on the initial installation. Security measures limit the operator(s) to the normal operating functions of the instrument, and to indicate if there is any unauthorized interference with system hardware or software settings after certification.
- ?? The instrument must be calibrated separately for Non-Approved Mode. You can switch between Approved Mode (LM 9000i) and Non-Approved Mode (LM 8000i) via the  key on the SETUP menu.
- ?? The calibration procedure is summarised in section 3.1. For full information on any of the settings in the calibration menu, excluding certification (section 3.2), please refer to sections 2.1 through 2.5.
- ?? **Once certified by your local weights and measures approval body, the system should not be re-calibrated or otherwise altered in any way, as the certification will become void. Re-verification by your local Approval Body is then necessary.**

Loadmaster 9000 DMM

The Loadmaster 9000 DMM is identical to the Loadmaster 9000i with the exception of the Store and Print functions.

All store references and load data are stored on the external Data Management Module. The store search and print functions are only available when the module is connected to the head unit.

1 Loadmaster 8000i Calibration

1.1 Calibration summary

The calibration procedure is summarised below. For full information on any of the settings in the calibration menu (see menu diagram overleaf), please refer to sections 2.1 through 2.5.

Step 1 Work the machine until it is up to the normal operating temperature.

Step 2 Go to the "Sensor Setup" menu (ref. section 2.1).

- (i) **Set "Ram Ratio"** The default value of 1.30 is OK initially, for almost all makes and models of machine. Known figures are given below.

Machine	Ram Ratio
VOLVO L120, L150	1.34
ALL KOMATSU	1.30
ALL CASE	1.30
ALL CAT MODELS	1.25

For other machines, you can determine the correct ram ratio by the following method: - Do a slow lift and then a fast lift. If the weight readings are the same, the Ram Ratio is correct. If the fast lift reading is greater then reduce the ram ratio, and vice versa.

- (ii) Set "Dual Sensor" to "DIFF".
- (iii) The default settings for "Live Static" (AUTO), and "Mode" (DYN/STAT) enable both dynamic and static weighing modes, and a live readout for the "last bucket" weighing mode. If you require static weighing mode only or dynamic weighing mode only, you must change these settings accordingly.

NOTE: Some CASE and Liebherr machines should be operated only in Static weighing mode.

Step 3 Go to the "AutoCal" menu (ref. section 2.2).

Follow the screen prompts for the calibration routine ("Dynamic full Lift", "Static Full Lift", "Live Static Comp", Dynamic Empty Lift", "Static Empty Lift", "Zero" and then "Cal Weight"), to establish accurate weighing. To perform the weight calibration ("Cal Weight"), load the bucket (preferably to its full capacity) with a known weight of material.

NOTE: If you don't know the exact weight, you can make an estimate and then use the "NUDGE" facility afterwards to correct the calibration factors.

The calibration figures resulting from the AUTOCAL procedure will apply to loading attachments 'A' to 'H'. To ensure accurate results when using a different attachment, adjust the calibration using the NUDGE facility.

Step 4 Check the weight reading (ref. section 2.4)

Zero the system and load a truck. Note the weighbridge (weigh scale) reading against the instrument reading. If they are different, use the NUDGE facility to enter the two readings. The calibration factors are adjusted automatically.

Step 5 Operator Instruction.

Please discuss the loading sequence and loading routine with the operator(s) of the loading shovel. Ride with the operator and explain the weighing methods, auto kick-out, auto / manual entry, and the importance of smooth operation while weighing.

2 Loadmaster 8000i/9000i - Common Calibration

2.1 Sensor Setup

NOTE: LM 9000i: -The "Sensor Setup" is automatically configured when you select the "Certification" for the system. Please refer to Section 3 for configuration details.

Sensor setup should be done before any other calibration. The sensor settings apply regardless of which attachment is selected.

Select the 'Sensor Setup' screen (figure. 2).

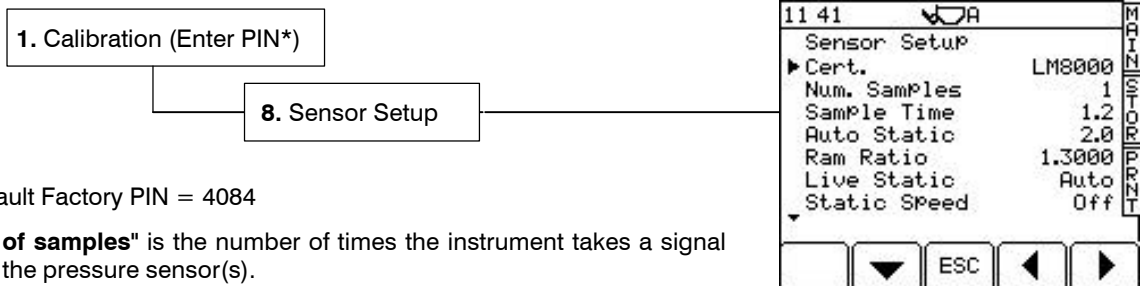

*Default Factory PIN = 4084

"No. of samples" is the number of times the instrument takes a signal from the pressure sensor(s).

"Sample Time" is the time taken for each sample in seconds.

"Auto Static" is the time delay after reaching the weighing position before the instrument samples the weight. This delay allows the system to settle down and helps to give consistent readings.

"Live Static" -The 'Off' setting has the effect of 'freezing' the weight reading when weighing in Static weighing mode. The 'On' setting allows a 'live' readout when the bucket is in the weighing position. This is not suitable for 'weighing on the move' operation. See '2.3.3 Static Compensation' for the best setup for 'live static' weighing.

NOTE: On the LM 9000i, the Live Static displayed weight cannot be entered into the total or printed out. It should only be used as a guide

"Static Speed" - Enables speed compensation for static weighing. This setting needs to be switched 'On' for certain machines, and in particular, CAT 966, 972 and 980 models. The majority of other loaders will not require 'Static Speed Compensation'

"Dual Sensor:" "Off" Single load sensor installation

"Dual" (Not used)

"Diff" Dual pressure sensor installations (Static or Dynamic operation). The second sensor measures back pressure on the return side of the lift ram circuit.

"Sum" Strain sensor applications. Sensor readings are added.

"Avg" Strain sensor applications. Sensor readings are averaged.

The 'Dual Sensor' setting should always be set to 'Diff'. This enables the system to zero at any lift speed and compensate for oil temperature (LM 9000i only).

"Ram Ratio" is the ratio of the area A1/A2 of each side of the ram piston (figure 3). The default value of 1.3000 is OK initially, for almost all makes and models of machine. You can determine the correct ram ratio by the following method. Do a slow lift and then a fast lift. If the weight readings are the same, the Ram Ratio is correct. If the fast lift reading is greater then reduce the ram ratio, and vice versa.

Figure 3

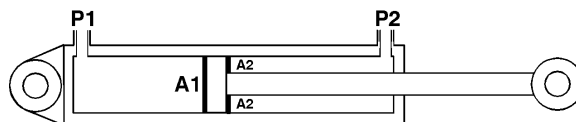

"Nudge Key" - The option to switch off the NUDGE facility so that it no longer appears on the 'SETUP' screen.

NOTE: LM 9000i: -The NUDGE facility must be switched "Off" after calibration has been completed.

"Zero Check" - Enables the "ZERO CHECK" function. (Default 'OFF' for LM8000i and default 'ON' for LM9000i).

"Mode" - This selects which weighing mode should be used. On LM 8000i models, "Dyn/Stat" is the default. "Dyn" only or "Stat" only can be selected.

"Angle Sensor" *Optional. Most LM 9000i installations*

Enables the angle sensor input and selects the vertical axis orientation of the sensor. Select the icon matching the orientation of the electrical junction box (looking forwards from the cab). Some Y(a)/Y(b) approved systems do not require an Angle Sensor to be fitted if slopes, during normal operation are below 5% (4.5°). Above this angle of operation, the angle sensor should be used.

"Sample type" : **"STD"** sets the system to sample a dynamic weigh procedure in the standard format, as used in the Loadmaster 8000 series with earlier S/W version PS300-026 rev.38

"ADV" sets the system to sample a dynamic weigh procedure in a new format. This mode should generally be selected, as it should be consistently more accurate in use.

Where this option is selected it will be necessary to mount the Ref / Dir sensors about 200mm from the boom pivot pin, centre, set.

"Bucket Sensor" *LM 9000i only*

Enables the bucket crowd sensor. Weighing will be inhibited unless the bucket is crowded back to the verified weighing position.

"Boom Sensor" *LM 9000i only*

"Temp. Sensor" *LM 9000i only*

Enables the temperature sensor. Weighing will be inhibited if the oil temperature falls below the "Inhibit Level" set on the "Temperature Factors" screen. Cold oil can affect the accuracy of the system.

2.1.1 General setup for loading shovels (LM 8000i)

Check that the initial settings are as given below. These are suitable for almost all makes and model of machine whether operated in Dynamic weighing mode or in Static weighing mode.

Setting	Dynamic or Static mode
Num. Samples	1
Sample Time	1.2
Auto Static	2.0
Ram Ratio	1.3000
Live Static	On
Static Speed	Off ('On' for CAT 966, 972 and 980)
Dual Sensor	Diff
Nudge	On
Zero Check	Off
Mode	Dyn/Stat
Angle Sensor	Off
Sample type	'ADV' (in accordance with Ref. /Dir. Sensor installation)

2.2 Auto Cal

After "Sensor Setup", do an "Auto Cal".

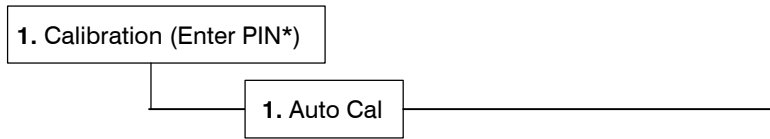

The instrument will automatically advance from Auto Cal step 1 ("Dynamic Full Lift") to step 7 ("Cal Weight"). "Angle Calibration" and "Temperature Calibration" follow on from "Cal Weight" on the LM 9000i. You can however, still select from the Auto Cal menu in any order.



Figure 4

2.2.1 'Dynamic Full Lift'

NOTE: LM 9000i: - Applies to AWI Y(y) modes only

LM 8000i: By default, dynamic speed compensation is switched off until the Auto Cal routine is performed.



Fast Speed calibration (Use Loaded Bucket)

Fill the bucket (you don't need to zero beforehand). With the menu pointer opposite the  symbol, lift the bucket at full speed. The instrument will beep once then display the frequency output of each pressure sensor, and the lift speed in milliseconds.

Press ENTER to confirm. The menu pointer will then move opposite the  icon and display the prompt "Slow Lift" (fig. 6).

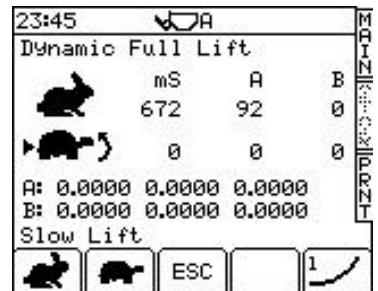



Figure 5

Slow Speed calibration

1. With the menu pointer opposite the  symbol, lower the bucket then slowly lift through the weighing position again. If you lift too quickly, the display will flash 'Error'. If so, lower the bucket and try again. The instrument will beep once, then display the frequency output of each pressure sensor, and the sample time in milliseconds (fig. 6a).
2. Press ENTER to confirm.
3. The instrument then displays the message "Speed Compensation Set".
4. Press the 'ESC' key to continue AUTOCAL ("Static Full Lift").

NOTE: The percent figures relate to the 'Proportional Scaling' function. This function predicts the difference in Speed Compensation required for light and heavy loads in the bucket. This compensates for hydraulic inefficiencies and the frictional behaviour of the lift system.

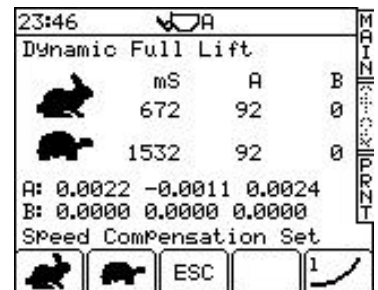

Figure 6a

2.2.2 'Static Full Lift'



NOTE: LM 9000i: - Will not be selected unless Dyn/Stat Setup (Sensor Setup) is used

LM 8000i: By default, Static Compensation is switched off until the Auto Cal routine is performed.

On machines where a substantial difference in displayed weight is experienced with changes in engine speed / speed of lift (for example G series Caterpillar loaders) this option can be turned to ON. Doing so will enable the Static Speed Compensation items within the Autocal menu and will turn on the Speed Compensated Static weighing function. This will allow the Loadmaster to apply a compensation value to the displayed weight based on the speed of lift, and should result in far more stable displayed weights where changes in speed of lift are experienced.

NOTE: This function is enabled only when the "Static Speed" setting on the "Sensor Setup" page is set to "On", otherwise this screen will not appear.

Follow the screen prompts.

-  Lift a **FULL** bucket at fast speed to the static weigh point (kickout), allow the system to weigh and then press ENTER.
-  Lift a **FULL** bucket at slow speed to the static weigh point (kickout), allow the system to weigh and then press ENTER. The instrument then displays the message "**Speed Compensation Set**" (fig. 6b).

Press the 'ESC' key to continue AUTOCAL ("Live Static Comp").

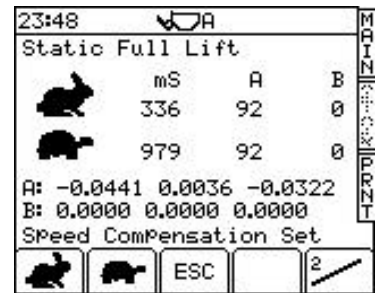

Figure 6b

2.2.3 'Live Static Comp'

By default, Static Compensation is switched off until the Auto Cal routine is performed.

Static compensation takes effect when the bucket is stationary at the weighing position. It enables the live static reading to become more stable over the sampling period and improves the accuracy of the weight reading.

Calibration is fully automatic. At the screen prompt, lift a FULL bucket SLOWLY to the weighing position. The screen then plots two graphs each with 30 samples for load sensors A and B (something similar to fig. 7). The calibration routine runs for 45 seconds and then displays the message 'Calibration Done'.

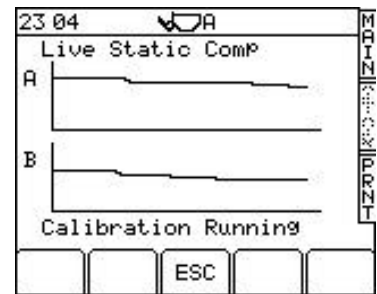

Figure 7



Press the 'ESC' key to continue AUTOCAL ("Dynamic Empty Lift").

2.2.4 "Dynamic Empty Lift"

NOTE: LM 9000i: - Applies to AWI Y(y) modes only

This function is active only when the "Dual Sensor" setting on the "Sensor Setup" page is set to "Diff". Diff. Setup compensates for oil temperature (LM 9000i only) and backpressure fluctuation in the hydraulics.

Follow the screen prompts.

-  Lift an **EMPTY** bucket at fast speed and press ENTER.
-  Lift an **EMPTY** bucket at slow speed and press ENTER.

The instrument then displays the message "**Calibration Done**" (fig. 8a). Press the 'ESC' key to continue the Auto Cal. ('Static Empty Lift').

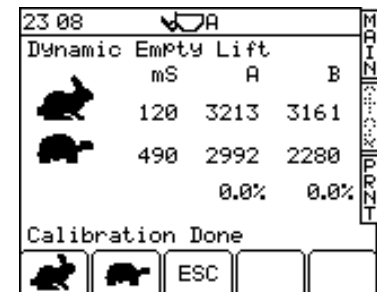



Figure 8a

2.2.5 'Static Empty Lift'

NOTE: This function is enabled only when the "Static Speed" setting on the "Sensor Setup" page is set to "On", otherwise this screen will not appear.

Follow the screen prompts.

-  Lift an **EMPTY** bucket at fast speed to the static weigh point (kickout), allow the system to weigh and then press ENTER.
-  Lift an **EMPTY** bucket at slow speed to the static weigh point (kickout), allow the system to weigh and then press ENTER. The instrument then displays the message "**Calibration Done**" (fig. 8b).

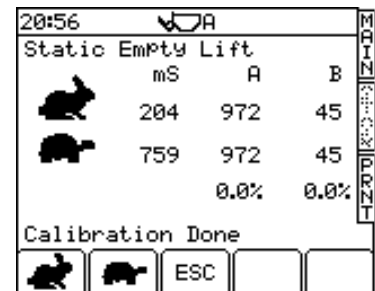

Figure 8b

2.2.6 Zero

NOTE: For LM 9000i:

With NAWI (IIII) setting, only the Static Zero routine applies.

With AWI (Y(y)) settings, only the Dynamic Zero routine normally applies, However if a DYN/STAT mode is selected for "Last Bucket" operation, the operation will be the same as the LM 8000i shown below.

1. Lift the empty bucket at maximum speed. The instrument will bleep once when the weight is taken. ENTERING to set "Dynamic Zero" is automatic.
2. Lift the bucket to the weighing position. The instrument will bleep twice. ENTERING to set "Static Zero" is automatic.
3. Press the "ESC" key to continue AUTOCAL (Cal Weight).

NOTE: For LM 9000i systems, the initial zero routine (on verification) sets up the "Zero Tracking Device". The initial zero reading is recorded on verification. The zero tracking device compares all subsequent zeros during normal operation, to this initial zero. If the variation exceeds certain limits., the system will error (ref. section 3.5 of the Operation manual).

Sticky material, bucket wear, or faulty electronics can cause variation from zero. Zero the system for each each different attachment used. Zero measurements are viewed on the "Dynamic Factors" and "Static Factors" screens.

2.2.7 Cal Weight (Weight Calibration)

If both dynamic and static weighing (Dyn/Stat) mode is enabled, then both a dynamic calibration routine and static, weight calibration routine are performed. If either dynamic weighing only ("Dyn"), or static weighing only ("Stat") mode is set, then the appropriate calibration routine will apply.

1. Zero the empty bucket.
2. Load the bucket (preferably to its full capacity) with a known weight of material.

NOTE: If you don't know the exact weight, you can make an estimate and then use the "NUDGE" facility afterwards to correct the calibration factors.

3. Select the "Cal Weight" screen (fig. 9).



Figure 9

Dynamic Calibration Routine

NOTE: If you want to do the static calibration first, press the  key.

For LM 9000i with AWI Y(y) settings, normally Dynamic Weight Calibration applies only. (If Dyn/Stat mode is selected for "Live Last Bucket", both Dynamic and Static routines should be performed.

For LM 9000i with NAWI (IIII) settings, only the Static Weight Calibration applies.

 indicates that speed compensation is enabled.



Figure 10

4. Lift the bucket at maximum speed through the weighing position. The screen will display a weight reading and the message 'Enter New Load' (fig. 10).
5. Key-in the known weight (or the estimated weight) and press ENTER. The instrument now calculates the Dynamic Cal. factor based on the weight entered. The screen will display the message "Confirmed".

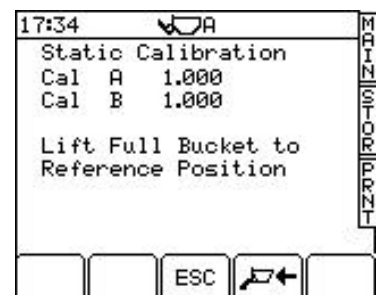

Figure 11

Static Calibration Routine

Normally, the "Static Calibration" routine follows automatically after the Dynamic calibration routine (see note above). The message "**Lift Full Bucket To Reference Position**" is displayed (fig. 11).

6. Lift the full bucket to the weighing position. The display will give a weight reading and the message "**Enter New Load**" (fig. 12).
7. Key-in the known weight (or the estimated weight) and press ENTER. The instrument now calculates the Static Cal. factor based on the weight, then displays the message "**Calibration Done**".
8. Press the 'ESC' key to continue AUTOCAL (Angle Calibration).

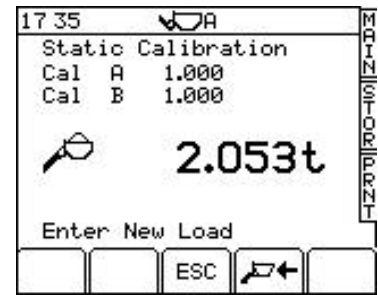

Figure 12

NOTE: LM 8000i: - The Angle Calibration routine and Temperature Calibration routine are disabled. Pressing the "ESC" key returns you to the AUTOCAL menu. Alternatively, exit calibration mode by selecting the MAIN screen.

2.2.8 Angle Calibration (LM 9000i -optional on LM8000i)

Note: All factors in the "Angle Factors" screen should be manually set to zero (except the Alarm Threshold Angle which is 10° by default) before carrying out the angle calibration. This is especially important if you have to recalibrate the angle compensation, after the first attempt was incorrect.

Calibration consists of a Zero routine (you have the option to skip this step) followed by five lift sequences. The live readings of both angles are displayed in the box.

shows dynamic weighing mode is selected. Press and hold the key to switch between static and dynamic weighing (LM 8000i only). Only Dynamic or Static compensation should be carried out, not both. If mainly weighing Dynamically, carry out this procedure dynamically, and vice versa.

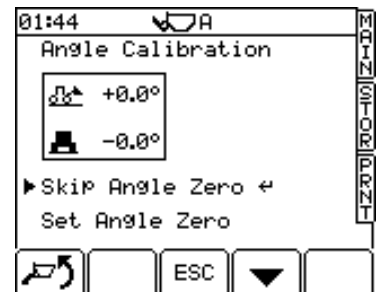

Figure 14

Zero

1. Select "Set Angle Zero" using the down arrow key and press ENTER.
2. Park the loader on level ground. Press the ENTER key to zero both offsets. The next screen is then displayed (fig.15).

The icons = 0° & = 0° at the bottom of this and subsequent screens indicate the required position and the present angle.

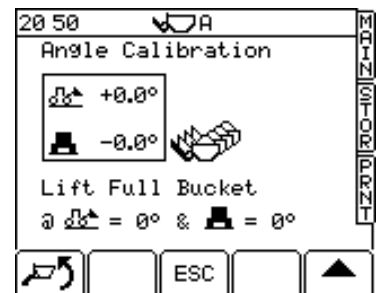

Figure 15

3. With the loader still on level ground, lift a ³/₄ full bucket. A weight is displayed. Press ENTER to confirm and move to the next screen.

NOTE: If either slope angle indicated inside the box is over 2 degrees, a warning triangle flashes on-screen, and the appropriate icon flashes inside the box.

4. Move the machine so that it is on a forward slope (i.e.8°), following the icons on the lower part of the screen. The adjacent slope (i.e. right hand/left hand) should be not more than 2 degrees off level. Again, the warning triangle will flash if the angle is exceeded. Repeat the lift and press ENTER to confirm and move to the next screen.
5. Repeat the lift sequence as prompted by the calibration screens, on a backward slope, then a right hand slope, and finally a left-hand slope.

When the last lift is entered, the screen will display the message "Angle Calibration Complete".

6. Press the 'ESC' key to finish AUTOCAL .

If a re-calibration is required, all factors on the ANGLE FACTORS page must be manually set to ZERO before carrying out the procedure again.

2.2.9 Temperature Calibration (LM 9000i only)

Not normally required as it is a "plug in and go" sensor. If necessary carry out the following:

Perform the calibration with the temperature sensor positioned in free air, i.e. not clamped to the hydraulic pipe. The screen will display a live temperature reading in the box (fig. 16a).

Measure the ambient air temperature and enter the reading.

Press the 'ESC' key to return to the "Calibration" menu.

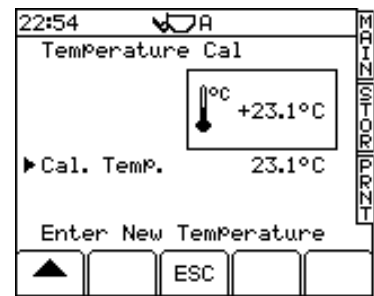

Figure 16a

2.3 Calibration Factors

The previous pages cover "Sensor Setup" and "Auto Cal" on the "Calibration" menu. With the exception of "6. Surge Factors", the menu items,

2. Static Factors
3. Dynamic Factors
4. Dyn. Comp. Factors
5. Stat. Comp. Factors
6. Surge Factors
7. Angle Factors

simply display the factors resulting from the Auto Cal routine for the attachment selected. Also, Speed compensation/Static Compensation can be switched on or off.



Figure 16b

2.3.1 Displaying Static/Dynamic Factors

These are the factors resulting from the AUTOCAL routine. From the "Calibration" menu, select "2. Static Factors" or "3. Dynamic Factors" to display them (fig. 17a). The Zero factors are also stored here. The first Zero factor (for both A and B sensors) refers to the initial Autocal Zero which is carried out on initial verification. The second Zero factors is the frequency stored at the initial switch on bucket Zero. The third Zero factor is the frequencies stored during any other Zero routine. These are used to perform the Zero Setting Checks.

NOTE: For LM 9000i with NAWI setting, only Static Factors apply.



Figure 17a

2.3.2 Dynamic Speed Compensation Factors (Dyn. Comp. Factors)

NOTE: LM 9000i: - Applies to AWI mode only

From the "Calibration" menu, select "4. Dyn. Comp Factors". There are two screens displaying various factors that can be edited if required (17b, 17c). Press  to advance to the second screen.







Figure 17b



Figure 17c

The first screen enables Dynamic Speed Compensation and Proportional Scaling to be switched on or off.

NOTE: There are two Speed compensation options: - "Type 1" and "Type 2". After performing the Auto Cal routine, Speed Compensation is automatically set as "Type 1" (). For hydraulic systems, Type 1 () should be set.

The second page shows the lift speed alarm limits in milliseconds. If the lift speed between the reference sensor and the direction sensor is faster than the "Fast Time" (the smaller value), the  symbol appears on the MAIN screen. If the lift speed is slower than the "Slow Time" (the larger value), then the  symbol is displayed.

"Curve A" and "Curve B" give the correction for the change in lift speed. If a fast lift gives a lower weight reading than the slow lift, then the figure should be decreased, and always -ve e.g. changing -11.0 to -10.0.

Proportional Scaling

Proportional Scaling is used to compensate for efficiency losses in a dynamic or static lift, and is a scaling factor based on the maximum load of the machine. It is important to perform the Speed Calibration routine with the maximum load in the bucket.

The "Prop" factors give the reduction in speed compensation for an empty bucket compared to a full bucket. Sometimes after an autocal, it is found that the speed correction with a full bucket is OK, but with an empty bucket there is a larger error (e.g. 50 to 60 kg).

If with an empty bucket, the weight reading is lower at a slower lift speed than at a fast speed, then reduce the "Prop A" factor by 2 - 3% until the error is removed. "Prop B" for hydraulics, is normally left at 0.00.

The normal setting for "Prop. Scaling" is "On".

2.3.3 Static Speed Compensation Factors (Stat. Comp. Factors)

From the "Calibration" menu, select "5. Stat.. Comp Factors". There are three screens displaying various factors that can be edited if required. Press  to advance to the second screen.



Figure 18a

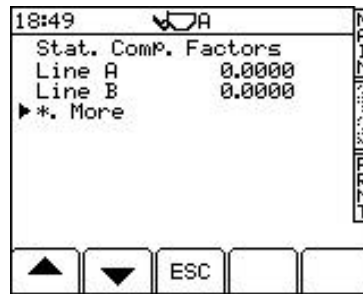

Figure 18b

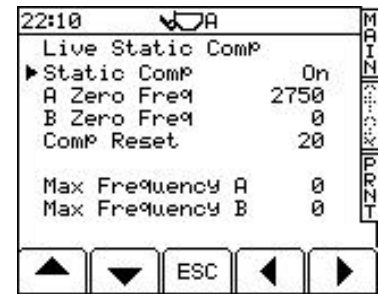

Figure 18c

The Static Comp Factors section consists of three pages of factors.

Page one (fig 18a) sets the speed compensation On or OFF, and allows access to the Proportional Scaling factors. Tests so far have indicated that there is no advantage to be gained from using the 'Curve' function when compensating for lift speed changes in Static weighing, so the recommended compensation system is the less complicated 'Line 2' setting.

Page two (fig. 18b) allows access to the speed compensation graph gradient factors ('Line A' / 'Line B').

NOTE: 'Line A' is the factor that should be edited to change the degree of Static Lift Speed compensation where editing is required. If a fast lift gives a lower weight reading than the slow lift, then the figure should be decreased, and always -ve e.g. changing -11.0 to -10.0.

Page 3 (fig. 18c) displays the Static Last Bucket live reading compensation values. These factors are display only and cannot be edited.

"Off / On / Auto" (third screen page)

Some machines using the live static mode may operate more accurately if "Static Comp" is set to "Auto". Set "Static Comp" to either "On" or "Auto", whichever suits the particular machine.

"Off" No compensation

"On" Uses the calibrated pressure drop compensation curve calculated from the autocal. With the LM 8000i, it is automatically switched on when the Auto Cal is performed.

"Auto" Produces a live reading, but the reading will only change if there is a change of 5% or more in the calculated weight.

A / B Zero Freq.

Zero signal from the sensors.

"Max Freq A / B"

Variable compensation is required depending on the load. The Max Frequency figures log the signals at Max load. This is set up from the 'Static Comp.' routine in the AutoCal.

In order for the instrument to know when it is lifting a fully loaded bucket (to apply the correct compensation), the maximum signal from each load sensor is saved here.

"Comp Reset"

If the frequency changes by a set amount on sensor A over the sample time, the compensation resets itself to the beginning of the routine. This is normally due to a pressure surge after the bucket is crowded back.

The default is 20 Hz (LM 8000i) & 0 Hz (LM 9000i), with "0" being "Off", Max figure 100 Hz.

NOTE: On LM9000i systems (Class III), switch off "Comp Reset" (set to zero) for discrimination testing (see "LM9000 Field Verification" manual).

2.3.4 Surge Setup (optional on LM 8000i)

This enables the instrument to detect a pressure surge due to machine bounce or acceleration, which may cause an inaccurate weight calculation. If the pressure surge exceeds an upper or lower limit, a warning **"TOO MUCH BOUNCE"** is displayed on the MAIN operating screen and weighing is inhibited.

The default setting is "On" for the LM 9000i. For the LM 8000i, this is normally switched off. It should only be used if necessary. Start with the default settings.

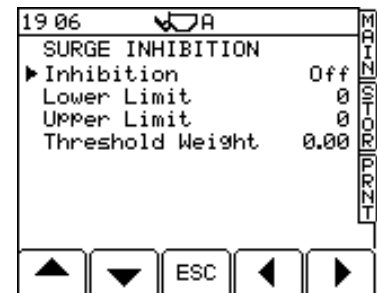

Figure 19

"Upper Limit" / "Lower Limit"

The "Lower Limit" figure (Hz) is used when the bucket weight is below the "Threshold Weight". The "Upper Limit" is used when the bucket weight is above the "Threshold Weight".

Raising the settings produces a less sensitive Surge Inhibit Alarm

Pre-set values are defined by the certification option selected (section 3.3.1) from the "Sensor Setup" menu. Once the machine is used, the upper/lower limits can be adjusted if necessary.

"Threshold Weight"

The threshold weight = 50e. E.g. if the Scale Interval 'e' is 20kg, then the threshold weight is 1 tonne.

2.3.5 Angle Factors (Optional Angle Sensor)

Weighing is inhibited when the system is used at angles exceeding those set on this screen (fig. 20). An alarm will sound and the angle error will be displayed on the MAIN operating screen.

 indicates the angle at which weighing will be inhibited.

The other compensation factors are calculated from the angle compensation routine in Auto Cal.

NOTE: If re-calibration of the angle factors is required, make sure that all the factors for Up/Down/Right/Left are manually set to zero before carrying out an AutoCal.

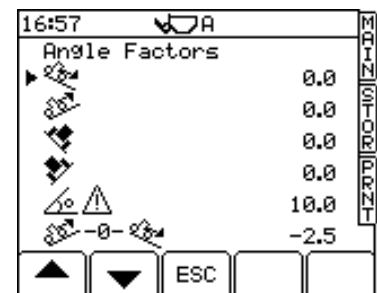

Figure 20a

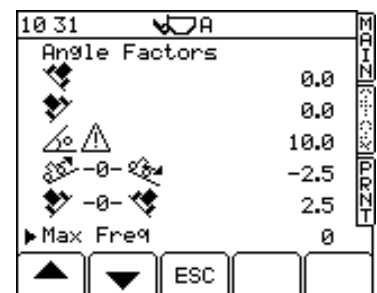

Figure 20b

2.3.6 Temperature Factors (LM 9000i only)

The default setting is "On" (this facility is switched on or off by the "Temp Check" function in the "Sensor Setup" menu).

From the "Calibration" menu, select "9 Temperature Factors". The screen displays the factors for the setup of the temperature sensor input (fig. 21a).

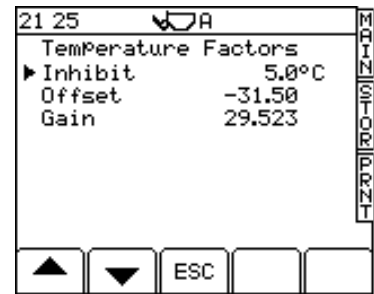

Figure 21a

"Inhibit" threshold

The weighing operation is inhibited if the temperature is below the "Inhibit Level", until the temperature raises above the specified level again. The prompt "Oil too Cold" appears on the MAIN operating screen.

NOTE: When the oil temperatures rises back above the "Inhibit Level", the "CHECK ZERO" routine is displayed. Normal weighing cannot commence until this routine is completed.

"Offset" Start point on the gradient

"Gain" Gradient Calibration Figure

"Temp Error" Message

If the signal falls to 0V or goes above 4.5V, "Temp Sensor Fault" is displayed on the MAIN operating screen, and weighing is inhibited until the signal falls within the limits.

The Default is 5 °C.

This setting depends on the make and model of the machine installed. The limit should be set to the lowest level of oil operating temperature within which the system will work to specification (normally 1/3 of operating temperature).

Changing Sensors.

Re-calibration is not normally required should this sensor fail.

2.3.7 Linear Factor

Normally there is a linear relationship in the weight to frequency calculation (fig. 21c).

However, on certain machines, and/or with wet, clayey materials, the relationship can become non-linear above a certain weight threshold.

If it is found that the weighing accuracy gets progressively worse above a certain weight, then you can enter a 'correction factor' to compensate for the error.

It is a process of trial and error to establish a suitable factor (%).

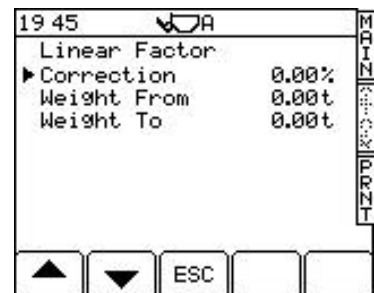

Figure 21b

"Correction" – Max +/- 5.0%. Correction of weight applied at load set in "Weight to".

"Weight from" ("Wf" on graph) **"Weight to"** ("Wt" on graph) – the range over which the correction factor is applied.

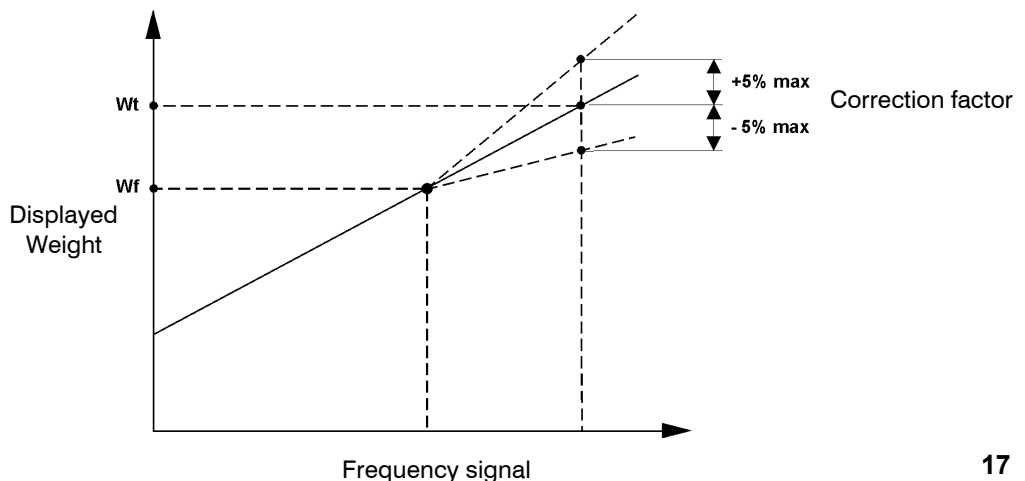

Figure 21c

2.4 'NUDGE' Calibration

You can nudge the calibration figures up to 10%. If the error is more than 10%, the instrument will prompt you to re-calibrate ("Cal Weight" in the Auto Cal menu).

This function is switched on or off from the 'Sensor Setup' screen in the SETUP menu. By default, it is switched on for the LM 8000i. For the LM 9000i, once calibration is completed and the loader is weighing with consistent accuracy, this function should be switched off to prevent further adjustments



When to nudge the calibration (LM 8000i only)

After performing the initial weight calibration and loading a few trucks, you may find that the load readings from the instrument are consistently different from weighbridge (weighscale) readings. This situation can also occur after maintenance or repair to the loading shovel e.g. changing a bucket.

How to nudge the calibration

1. Load a truck and note the weighbridge total against the instrument total for that load, e.g.

Scale reading:	24.78 tonnes
Instrument reading	23.96 tonnes

2. Press  to select the 'Nudge' screen (fig. 22).
3. Enter the instrument reading () and press ENTER (fig.23).
4. Enter the weighbridge reading () and press ENTER (fig 24).

The percentage difference between the instrument and weighbridge totals is then displayed. Press the ENTER key to confirm. All dynamic and static factors are automatically re-calculated and stored in memory. The screen displays the message 'New Factors Set'.

5. Press the "ESC" key to return to the "SETUP" menu screen, or select the MAIN weighing screen to exit Calibration mode.



NOTE: To nudge the calibration by a known percentage, enter 1.000 tonne for both the  and  figures, then enter the known percentage figure and press ENTER to confirm.



Figure 22

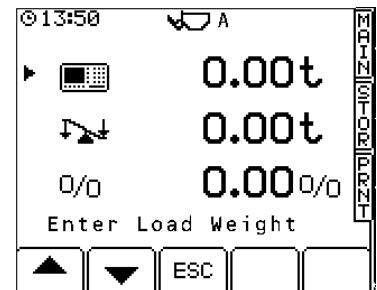

Figure 23

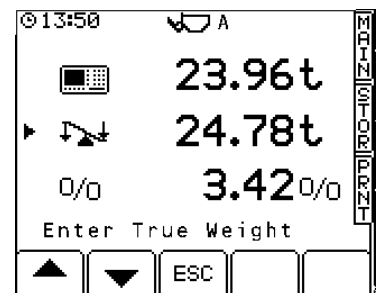

Figure 24

2.5 Calibrating alternative attachments

2.5.1 Programming an attachment

By default the LM8000i/9000i is programmed to recognise only one attachment. The Auto Cal routine will therefore calibrate for attachment 'A'. You can programme the instrument for up to 8 attachments as follows: -



1. From the "SETUP" menu, select "1. Calibration" (PIN entry required).
2. Press the  key (fig. 25) to select the "Attachment" screen (fig. 26).
3. Select from the list 'B' to 'H' using the arrow keys and then press the  key to switch on the attachment. Only those that are have a tick against them will appear to the operator via the  key on the SETUP menu.
4. If required, programme an attachment description (up to 20 alphanumeric characters). Simply position the flashing cursor under the attachment letter using the right arrow key; enter the description using the alphanumeric keypad. (For LM 9000i, enter the Serial No of the Attachment here)
5. Press "ESC" twice to get back to the "SETUP" screen.



Figure 25

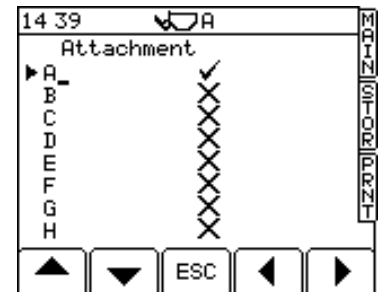



Figure 26

2.5.2 Select an attachment for calibration

1. From the "SETUP" menu (fig.27), press the  key to select the "Attachment" screen.
2. Simply select the appropriate one using the up / down arrow key, and then press "ESC". The instrument is now ready to be calibrated for that attachment.

NOTE: The current attachment is always displayed at the top of every screen.

2.5.3 Calibrating an alternative attachment

Select the attachment from the list,

In the Auto Cal, carry out the Zero function **only** to set the "Zero Tracking Device". (Picks up large Zero change during use).

Select the attachment from the list, and then use the NUDGE function to adjust the calibration. (No need to carry out Diff/Speed comp etc. in the AutoCal)

REMEMBER! You must re-calibrate using the NUDGE function, each time you change an attachment.

NOTE: If an attachment is subsequently repaired or modified in any way that affects its weight or centre of gravity (e.g. new bucket cutting edge, teeth etc), then it should always be re-calibrated



Figure 27



3 Loadmaster 9000i Calibration

3.1 Calibration Summary

The calibration procedure is summarised below. For full information on any of the settings in the calibration menu (see menu diagram overleaf), please refer to sections 2.1 through 2.5.

Step 1 Set the certification class required (Section 3.2.1), which, except for the "Ram Ratio", automatically configures the settings in the "Sensor Setup" menu. This also sets up the correct Verification Divisions (e), Maximum/ Minimum weights and Overload point.

Step 2 Work the machine until it is up to the normal operating temperature.

Step 3 Go to the "Sensor Setup" menu (ref. section 2.1).

- (i) Set "Ram Ratio" The default value of 1.30 is OK initially, for almost all makes and models of machine. Known figures are given below.

Machine	Ram Ratio
VOLVO L120, L150	1.34
ALL KOMATSU	1.30
ALL CASE	1.30
ALL CAT MODELS	1.25

For other machines, you can determine the correct ram ratio by the following method: - Do a slow lift and then a fast lift. If the weight readings are the same, the Ram Ratio is correct. If the fast lift reading is greater then reduce the ram ratio, and vice versa.

For "AWI " Y(b) settings, the default is dynamic weighing only. If the "Live Last Bucket" facility is required, set the "Mode" to "Dyn/Stat"

Step 4 Go to the "AutoCal" menu (ref. section 2.2).

Follow the screen prompts for the calibration routine ("Dynamic full Lift", "Static Full Lift", "Live Static Comp", "Dynamic Empty Lift", "Static Empty Lift", "Zero" and then "Cal Weight"), to establish accurate weighing. To perform the weight calibration ("Cal Weight"), load the bucket (preferably to its full capacity) with a known weight of material.

NOTE: If you don't know the exact weight, you can make an estimate and then use the "NUDGE" facility afterwards to correct the calibration factors.

The calibration figures resulting from the AUTOCAL procedure will apply to loading attachments 'A' to 'H'. To ensure accurate results when using a different attachment, adjust the calibration using the NUDGE facility.

Step 5 Check the weight reading (ref. section 2.4)

Zero the system and load a truck. Note the weighbridge (weigh scale) reading against the instrument reading. If they are different, use the NUDGE facility to enter the two readings. The calibration factors will be automatically adjusted.

Step 6 Weights and Measures Approval - Field Verification is carried out by the local Approval Body.

Step 7 Switch off the "NUDGE" facility (section 2.1).

Step 8 Anti-tamper measures: (section 3.2.2).

3.2 Certification

There are currently 3 main Approval Certifications: -Class III - NAWI (Non-Automatic weighing Instrument), y(b) - AWI (Automatic Weighing Instrument) to OIML R51, and AWI to MID 2004/22/EC.

- ?? OIML R76 NAWI (Non-automatic Weighing Instrument), with maximum load weight from 1000 kg to 25000 kg.

Certification text: -  ("Class III Approved").

- ?? OIML R51/MID AWI (Automatic Weighing Instrument) with maximum load weight from 1000 kg to 25000 kg.

Certification text: - **y(b)** ("y(b) Approved").

3.2.1 Setting the Certification Defaults

For ease of setup, the instrument is configured for certification in the range 1 to 15 tonnes via a menu of 18 presets (see below). It is also possible to configure the Loadmaster 9000i for any maximum weight from 16 to 25 tonnes, but not via presets.

Select the "SENSOR SETUP" page: -

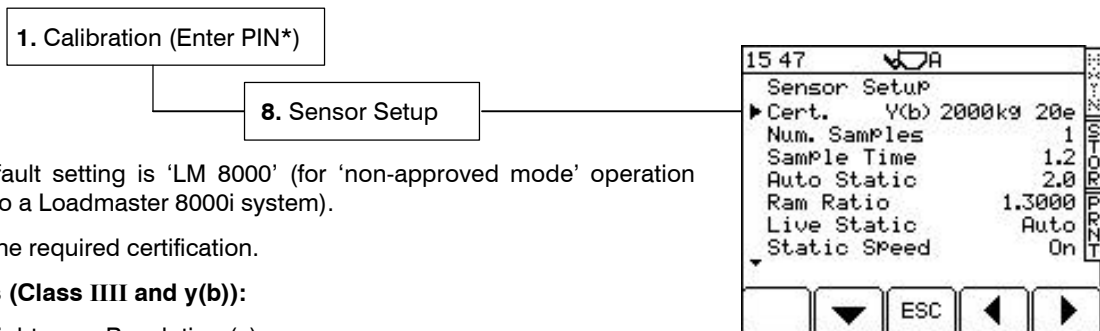

Figure 28a

The default setting is 'LM 8000' (for 'non-approved mode' operation similar to a Loadmaster 8000i system).

Select the required certification.

Presets (Class III and y(b)):

Max weight:	Resolution (e):
1000 kg	10kg (10e)
2000 kg	20kg (20e)
3000 kg	
4000 kg	
5000 kg	
5000 kg	50kg (50e)
6000 kg	
7000 kg	
8000 kg	
9000 kg	
10000 kg	
11000 kg	
12000 kg	
10000 kg	100kg (100e)
11000 kg	
12000 kg	
13000 kg	
14000 kg	
15000 kg	
17000 kg	
20000 kg	
25000 kg	

NOTE: A non-approved setting "Y(b) 20000kg 10e" can be selected if the system is to be used, but not verified, for "Trade". This allows full operation of the system with no "Minimum Weight" settings

The default settings are as follows: -

OIML R76 NAWI (Class III), (1000 to 25,000kg)

Display Resolution 'd' = 'e' = 20 kg, 50kg or 100kg
Resolution (RES) button displays to nearest 0.1e
Maximum weight - Max. Certified weight + 9e
Static weighing only (no last bucket facility)(Live Static OFF)
Bucket sensor - ON
Surge Inhibit - ON
Check Zero - ON
SI Unit - "t" (tonne)
Angle - ON
Auto Enter - manual
Dual sensor - Diff
Weight Threshold - 50e
Print Inhibit - 0.00 (Off)
Cert. Text - Class III Approved

NOTE: *With all NAWI setups, the "Diff Comp", "Speed Comp.", "Dynamic Zero" and "Dynamic Cal Weight" functions are disabled, and it is not possible to enter these modes. All Cal factors referring to these modes are also inaccessible.*

OIML R51 AWI (y(a)/y(b) (1000 kg - 25,000 kg)

Display Resolution - 'd' = 'e' = 20 kg, 50kg or 100kg
Resolution (RES) button provides to the nearest 0.1e ("t" is dropped off display)
Maximum weight - Maximum certified weight +9e (Inhibit Weighing above this weight)
Dynamic weighing only (no last bucket facility)(Live Static OFF)
Bucket sensor - ON
Surge Inhibit - ON
Check Zero - ON
SI Unit - "t" (tonne)
Angle - ON
Auto Enter - Auto (last bucket manual)
Dual sensor - Diff
Weight Threshold - 50e
Print Inhibit - 10e (No printing capability below this weight.)
Cert. Text - Y(b) Approved

NOTE: *In all AWI setups, Static Calibrations in the AUTOCAL and Cal Factors are inaccessible.*

3.2.2 Completing the Data Plate and Anti-tamper Measures

Once the system has been tested and verified by the Approvals Body, do the following: -

OIML R51 (Class III) Data Plate:

?? Stamp the certification parameters (Min. Weight, Max Weight, Verification Scale Interval (e)) onto the self-adhesive Data Plate (figure 28b), which is then applied to the left hand side of the head unit.

NOTE: *You only need to stamp lightly*

?? In the case of Class III verification, apply the Type Approval sticker (Green Metrologie symbol) onto the space provided on the plate. The sticker is not used for y(b) verification.

MID Y(b) Data Plate:

Using an indelible, black ink pen, write the certification parameters onto the self-adhesive Data Plate (figure 28c), which is then applied to the left hand side of the head unit.

Figure 28b : OIML R51 (Class III) Data Plate

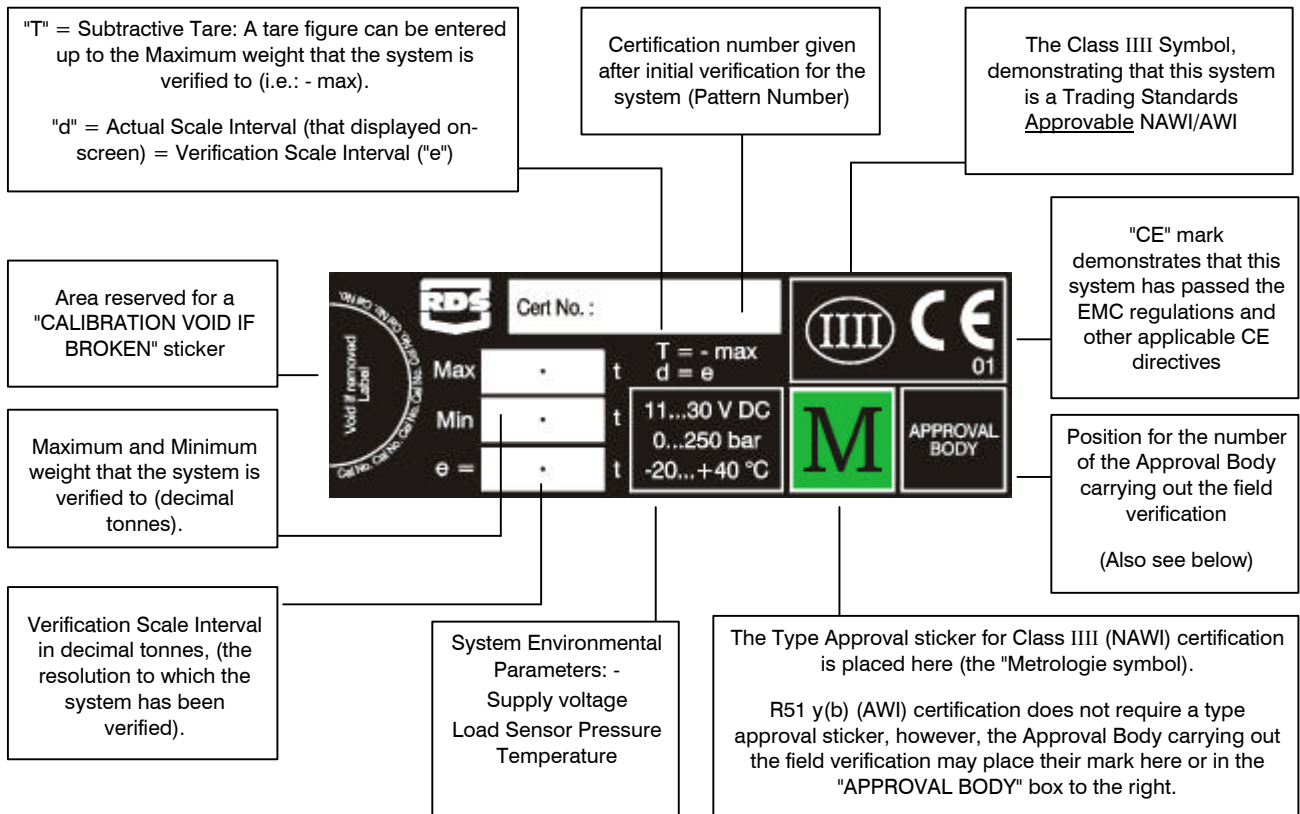
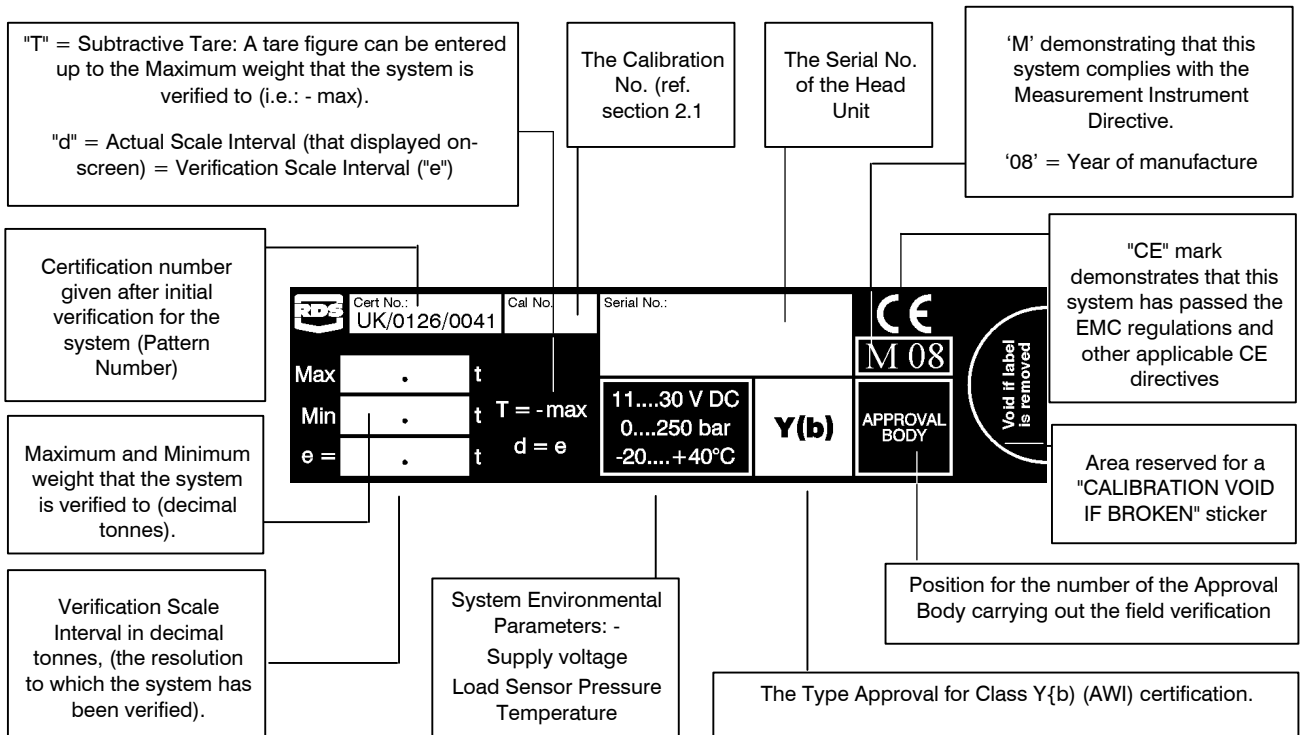

Figure 28c: MID Y(b) Data Plate



- ?? The Approval Body will apply their mark in the space marked APPROVAL BODY.
- ?? Apply the "CALIBRATION VOID IF BROKEN" sticker (fig. 28d) across the edge of the certification plate where indicated. Note the "Cal No". at the bottom of the screen when you switch the instrument on. Mark this number onto the "CALIBRATION VOID IF BROKEN" sticker in indelible pen. Also make a note of this number elsewhere for future reference.



Figure 28d

Every time the calibration mode is accessed, the calibration number will increment. Therefore, any further unauthorised attempt to change a PIN protected calibration setting will be evident at the next service call.

- ?? Enter the component serial numbers into the instrument:-

Secondary Software Module	<input type="text"/>
Pressure Sensor P1 (Lift side)	<input type="text"/>
Pressure Sensor P2 (Return side)	<input type="text"/>
Junction Box	<input type="text"/>
Bucket Crowd Sensor	<input type="text"/>
Reference/Direction Sensor	<input type="text"/>
Angle Sensor	<input type="text"/>
Temperature Sensor	<input type="text"/>

4 LM8000i / LM9000i - General System Settings

4.1 Output Port Setup (LM8000i / 9000i)

NOTE: Requires the Technician PIN number (default = 1234)

There are two 9-way ports on the back of the instrument.

Port 1 is the upper port.

Port 2 is the lower port.

From the SETUP menu, press,

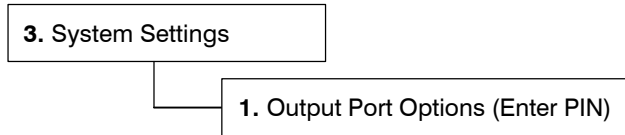

NOTE: Port 1 and port 2 have an additional configuration for "Screen" output. This option is not applicable in normal use.

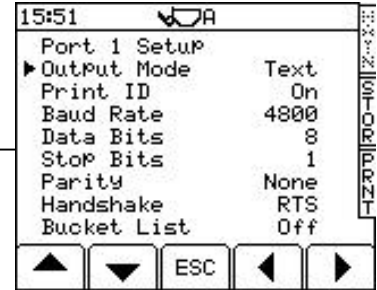

Figure 29

The top port is factory set for connecting an RDS ICP printer, without further configuration being necessary. If another printer is used (or you want to select an option other than a printer), you can configure the settings from the 'SETUP' menu (ref. the Calibration manual).

Port Output Mode	Port function
'Text'	Printer
'Data'	Direct cable link to PC
'Card'	Top Port :- External Data Card Module Bottom Port:- No external function – enables the internal SD Data Card Module
'Radio'	Telemetry via radio
'GSM'	Telemetry via mobile phone
'Screen'	(For RDS use only)

4.1.1 Set Output Mode

ASCII Text Output for Printers

Set the output mode to "Text". The data is output as ASCII text formatted to suit the RDS ICP 200 In-Cab Printer.

NOTE 1: Print Inhibit: (LM 9000i y(b) (AWI) mode only). In AWI mode, printing is inhibited when the weight total is less than 10e, and cannot be added to the totals.

The default settings (fig. 29) are for the RDS ICP 200 In-Cab Printer.

- Print ID **Off / On**
- Baud rate: 110 / 150 / 300 / 600 / 1200 / 2400 / **4800** / 9600 / 19,200 / 31,250 or 38,400.
- Data Bits: 7 / **8**
- Stop Bits: 1 / 2
- Parity: **None** / Odd / Even
- Handshake: **RTS** / XON
- Bucket List **Off/On**

NOTE 2: "Print ID" switches the "Instrument ID" function (ref. the Operation manual section 5.4) on or off. When switched off the "Instrument ID" text (up to two lines each of twenty characters) will not appear on the printout.

NOTE 3: If you are using an existing printer from another manufacturer, it may operate with a different protocol. If it does not work with the default settings, please refer to the printer instructions.

NOTE 4: "Bucket List" provides an itemised list of all bucket lifts on a ticket (only possible in "Customer" mode).

Comma-delimited Output

Set the output mode to "Data". The data is output as a comma-delimited string, e.g. in a format compatible for import into a database program via a PC / PDA (Palm/Psion etc).

Input/Output to the RDS Data Card Module

Set the output to "Card". The instrument writes/reads files in .CSV format to/from the SD card.

Input/Output via Radio Modem (LM8000i / 9000i)

Set the output mode to "Radio" for telemetry via a radio modem. The range of a radio telemetry system generally limits use to a single site.

Input/Output via GSM Modem (LM8000i / 9000i)

Set the output mode to "GSM" for telemetry via a GSM device. Data can then be transmitted between any other site, since data is transmitted via the cellular telephone network.

NOTE: As well as configuring the appropriate output port for telemetry operation, the telemetry option must be switched on from the "System Settings" menu (section 4.6). Refer to the manual supplied with the telemetry kit for full information on telemetry operation.

All data contains security checksums. Deletion or modification invalidates saved or transmitted data !

4.2 Weighing Units

NOTE: The LM 9000i requires the Factory PIN to access the "Weighing Units" screen. The LM 8000i does not.

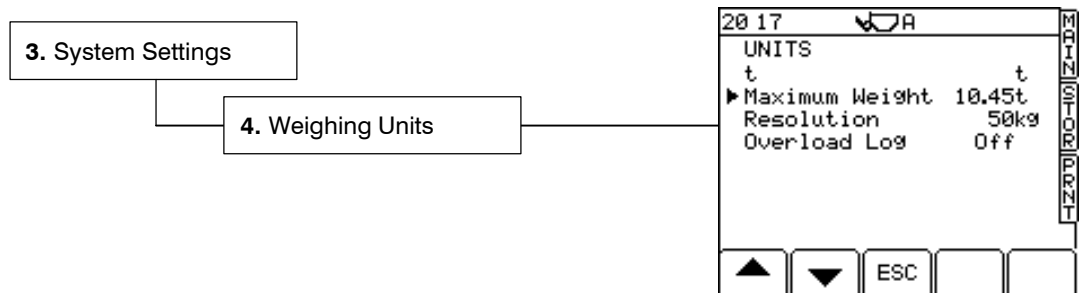

Figure 30

Units

LM8000i:- Choose units of either kg, lbs., UK tons, US tons, Metric tonnes or cubic metres. If you select volume (m³), then you set density from the MAIN operating screen (see Operating manual).

LM9000i :- For Approved Mode, units must be either kg or tonnes.

Resolution

NOTE 1: The weight total is rounded up or down, and it is this rounded off figure that is added to a memory total.

LM8000i:- For lbs. or kg units you can set the resolution, i.e. to the nearest 1, 5, 20, 25, 50, or 100 lbs. or kgs.

LM9000i:- When you select the required certification in the "Sensor Setup" menu, the display resolution is automatically set.

NOTE 2: When the LM9000i is used in "non-approved" (LM8000i) mode, the units are not displayed on screen or on a printout.

Maximum Weight

 flashes on-screen with a 3-second continuous beep when the maximum weight limit is exceeded. This will occur 9 divisions (9 x e) above the stated maximum figure that the system is certified to. Weighing is inhibited in NAWI or AWI mode.

Example: If Max weight = 10.0t and 'e' = 0.05t, the Alarm weight = 10.45t.

Overload Log

Switch "On" if you want the instrument to log any weight entered above the target weight.. The accumulated overload weight is displayed on the GRAND TOTAL page (ref. section 4 – Operation Manual).

4.3 Bleep Setup

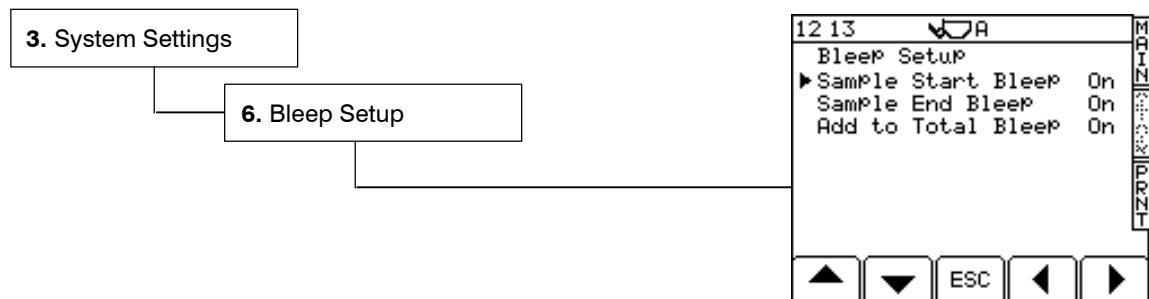

4.4 Change PIN Numbers

NOTE: Requires the Factory PIN number for access (default = 4084)

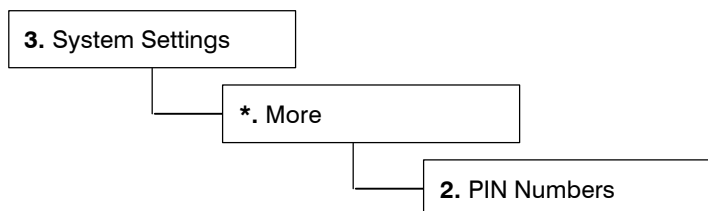

You can set new PIN numbers as required.

You can then choose to set either the "Technician Pin" (default = 1234) or the "Factory Pin" (default = 4084).

4.5 Reset Factors

NOTE: Requires the Factory PIN number (default = 4084)

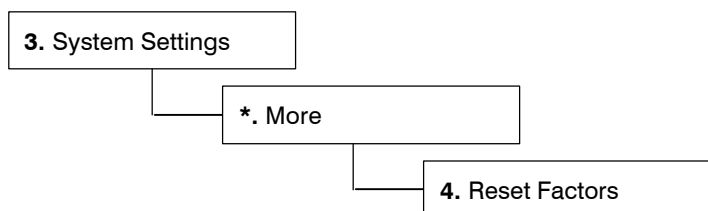

Follow the screen prompts to reset the instrument to the factory default settings.

NOTE: All customised factors including customer and stores data will be lost. It is recommended that you keep a record of the existing calibration data.

4.6 Store / Restore / Print Cal Data

NOTE: Requires the Factory PIN number (default = 4084)

The calibration factors are manually saved to memory store A. This data is NOT overwritten each time the instrument is switched off, but it WILL be cleared after a Total Software Reset ("RESET FACTORS"). If for example, any calibration data is unwittingly changed without keeping a record of previous settings or data is corrupted, you can restore the calibration data from either of these stores at any time.

NOTE: Should the instrument head unit fail, the module can be placed into a new head unit, keeping all relevant calibration data that is stored using this function. Once the module is re-installed, select "Restore from A". This will re-install all the original factors.

To store or restore Cal Data, press: -

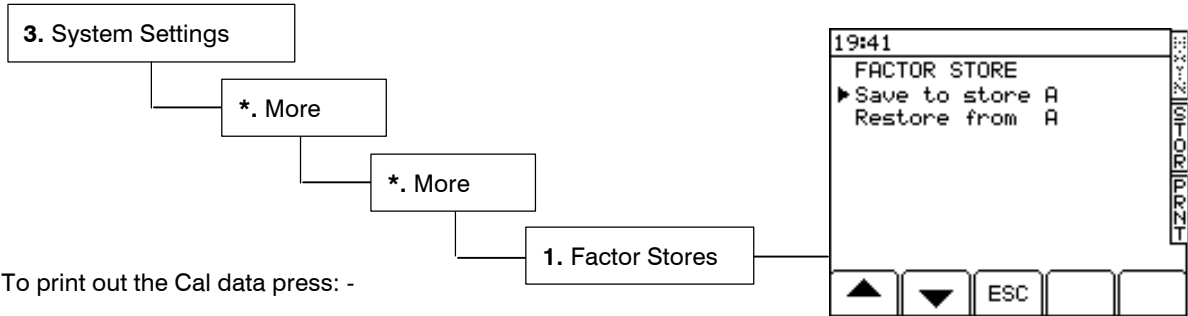
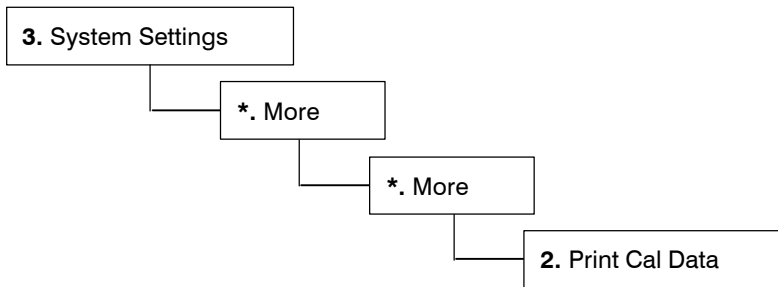

Figure 31

To print out the Cal data press: -



4.7 Telemetry Option - Enable/Disable (LM8000i / LM9000i)

As well as configuring the appropriate output port for telemetry operation (section 4.1), the telemetry option must be enabled.

Set to "On" for one way data transmission i.e. from the mobile unit to the base station.

Set to "Auto" for two way data transmission, i.e. for sending job information to the mobile unit.

Setting to "Off" disables the telemetry option.

NOTE: Refer to the manual supplied with the telemetry kit for full information on telemetry operation.

4.8 'Module'

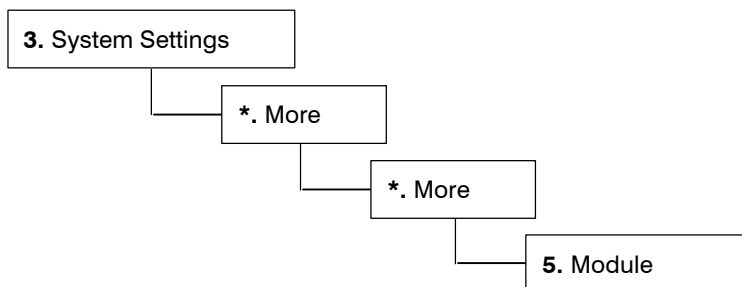

Enables access to the "Secondary Software Module" (the 'M' soft key is displayed on the setup menu screen).

5. The SETUP menu

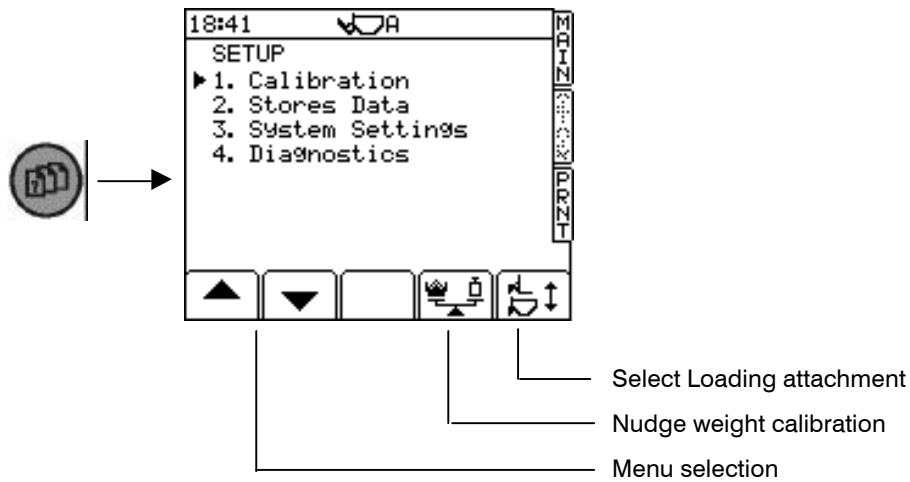

1 st Level	2 nd Level	Parameter	Settings - reference
1. Calibration	1. Autocal	1. Dynamic Full Lift	2.2.1
		2. Static Full Lift	2.2.2
		3. Live Static Comp.	2.2.3
		4. Dynamic Empty Lift	2.2.4
		5. Static Empty Lift	2.2.5
		6. Zero	2.2.6
		7. Cal Weight	2.2.7
		8. Angle Calibration	2.2.8
		9. Temperature Cal	2.2.9
		2. Static Factors	2.3.1
	3. Dynamic Factors	2.3.1	
	4. Dyn. Comp Factors	2.3.2	
	5. Stat Comp Factors	2.3.3	
	6. Surge Factors	2.3.4	
	7. Angle Factors	2.3.5	
	8. Sensor Setup	2.1	
	9. Temperature Factors	2.3.6	
	10. Linear Factor	2.3.7	
2. Stores Data	Product	Operation Manual	
	Customer		
	Reference 1		
	Reference 2		
	Reference 3		
	Reset to Undef		

1st Level	2nd Level	<i>Parameter</i>	<i>Settings - reference</i>
3. System Settings	1. Output Port Setup		4.1
	2. Display Settings	Brightness / Contrast	<i>Operation Manual</i>
	3. Time Set		<i>Operation Manual</i>
	4. Weighing Units		4.2
	5. Tare		<i>Operation Manual</i>
	6. Bleep Setup		4.3
	* More		
	↓		
	1. Instrument ID		<i>Operation Manual</i>
	2. PIN Numbers		4.4
	3. Language		<i>Operation Manual</i>
	4. Reset Factors		4.5
	* More		
	↓		
	1. Factor Stores		4.6
	2. Print Cal Data		4.6
	3. Print Store Names		<i>Operation Manual</i>
4. Telemetry		4.7	
5. Module (SSM)	On / Off	4.8	
4. Diagnostics			

6. Operating Parameters

The Loadmaster system is designed to operate within the following parameters:

Environmental:

Climatic environment:	Indicator, printer: Closed, non-condensing, -20/+40° C
Transducers, sensors:	Open, condensing, -20/+40° C
Sealing:	Head unit:: IP34 (mount in an enclosed cab) Sensors: IP67 (mount with hose connection uppermost) Junction Box: IP65
Pressure range:	0 – 250 bar
Maximum angle deviation	From level ground, ± 10° Front-Back, ± 5° Left-Right
Approval Classification:	OIML R51, Y(a)/ Y(b), MID Y(b), OIML R76
No. of divisions (n)	250
Scale Interval (e) (kg)	>/=10
Capacity (kg):	</= 25,000

Electrical:

Supply voltage:	11 – 30V dc
Current:	500mA max.
EMC Emission:	EN50081-1
EMC Immunity:	EN50082-2
EM classification:	E3

NOTES

Issue 1.3:	23/1/08	Original Issue (derived from UK273-6.DOC / UK576120.DOC)
Issue 1.31:	20/10/08	Minor corrections only
Issue 2:	10/11/08	Added environmental spec MID-compliant Data Label information
Issue 2.1	28/11/08	p.33: Added operating parameters. Fig 3b: deleted reference to "08"
Issue 2.2	22/12/08	Changes to pages 1,9,10,14,15,16,17,20,21,23,24,26,29
Issue 2.2.1	27/1/09	Reformatted page headers, Corrections ref. Section 1.1-step 3, Section 3.1-step 4, p.29, replaced figs 5 – 8b